

LIFTING BASKET (3.0 MT S.W.L.)  
FRONT EL VIEW  
(SCALE 1:20)

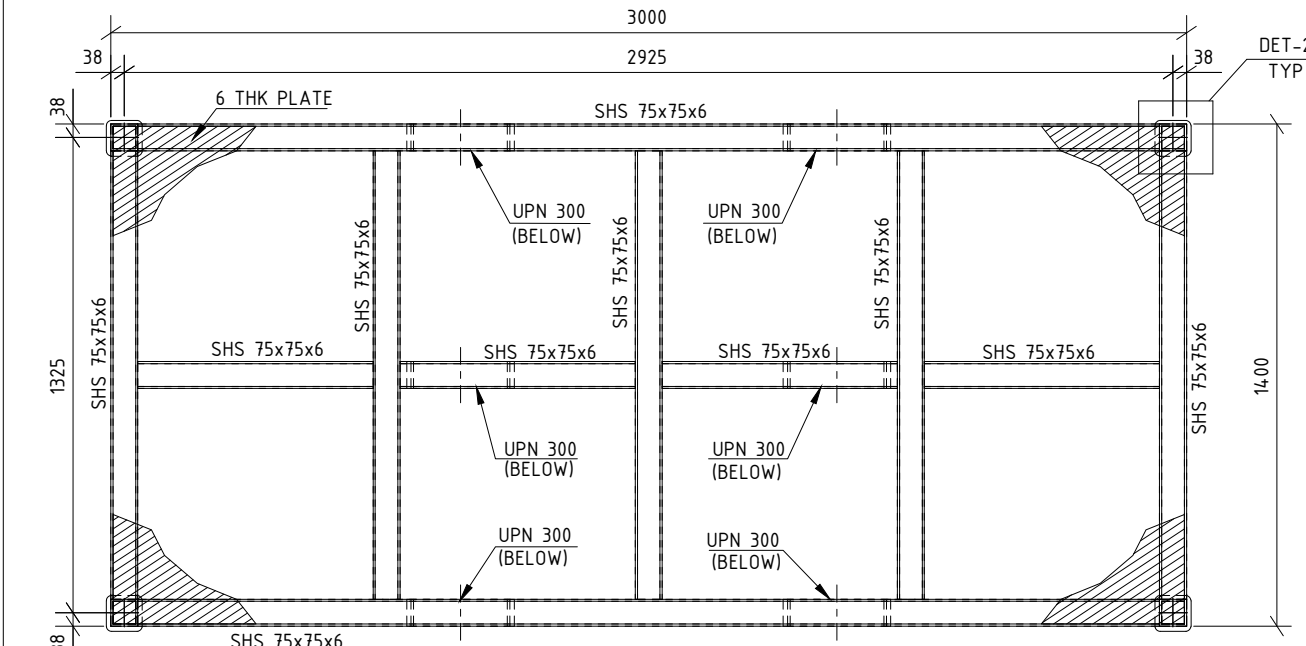

BOTTOM VIEW  
(SCALE 1:20)

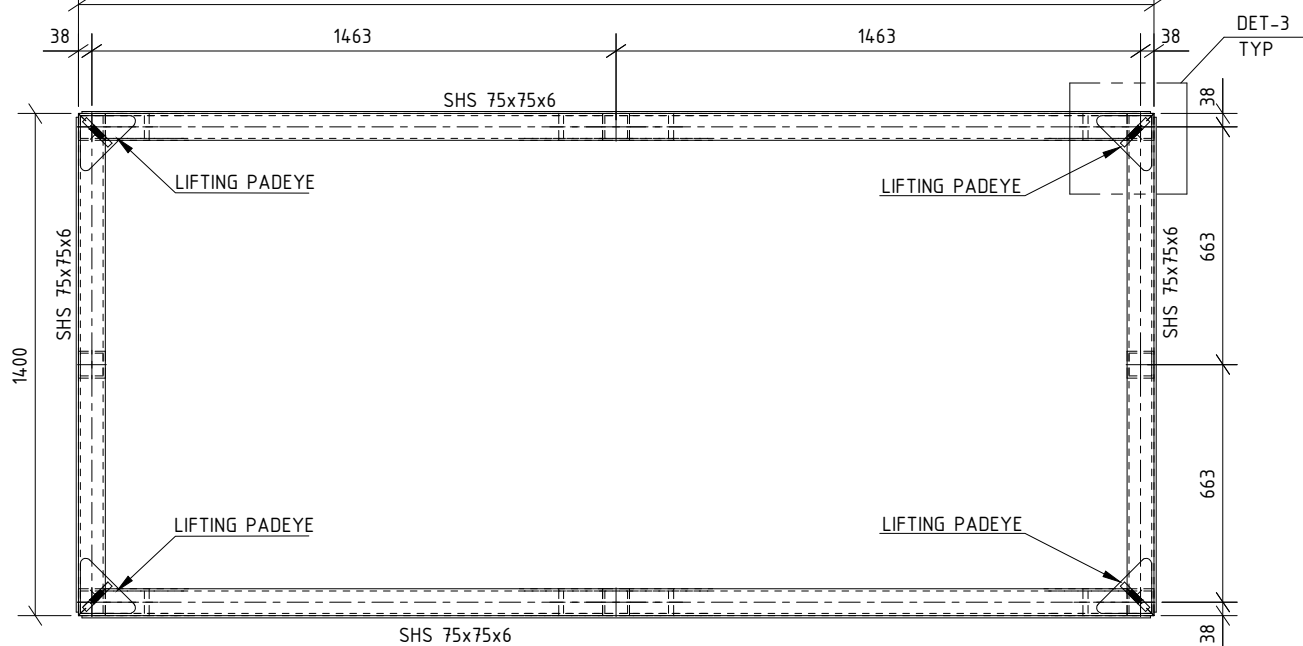

PLAN VIEW  
(SCALE 1:20)

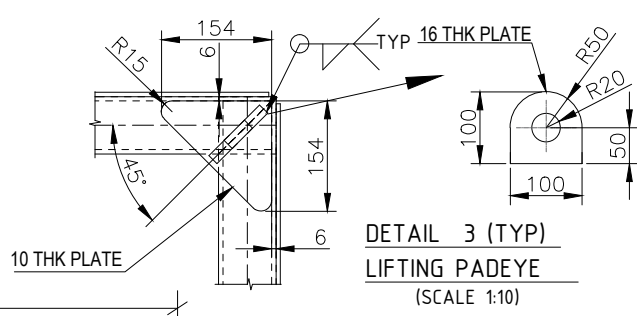

DETAIL 3 (TYP)  
LIFTING PADEYE  
(SCALE 1:10)

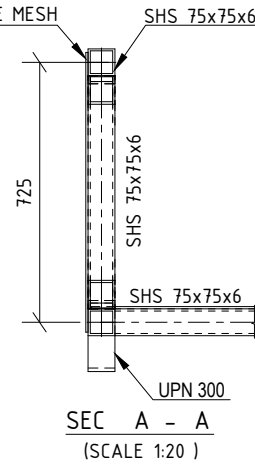

SEC A - A  
(SCALE 1:20)

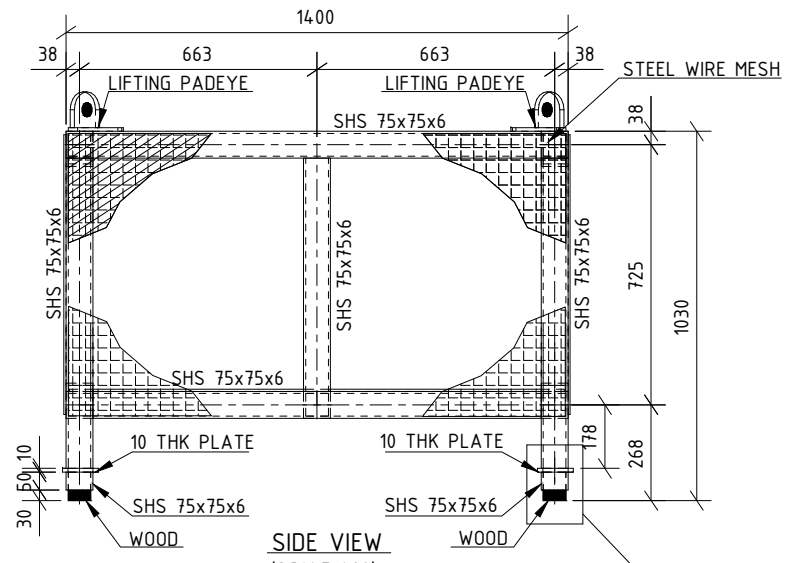

SIDE VIEW  
(SCALE 1:20)

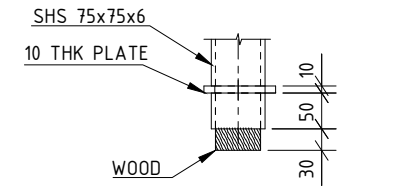

DETAIL -1 TYP  
(SCALE 1:10)

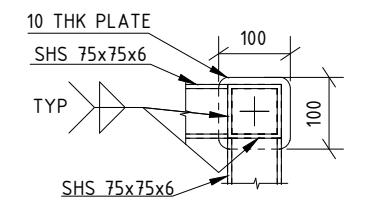

DETAIL -2 TYP  
(SCALE 1:10)

- NOTE:-
1. ALL DIMENSIONS ARE IN MM UNLESS NOTED OTHERWISE
  2. ALL MATERIALS TO BE NORMAL MILD STEEL (YIELD =235 MPa) U.O.N
  3. LEG LENGTH OF ALL FILLET WELDS TO BE  $t/2+15$ , WHERE 't' IS THE MIN. THICKNESS OF PLATE TO BE WELD OR 5mm, WHICHEVER IS GREATER
  4. BASKET TO BE PLACED ON EVEN GROUND.
  5. MATERIAL BASKET IS DESIGNED TO CARRY A PAY LOAD OF 3.0MT CAPACITY.
  6. DECK LOADING - 1.34 Ton/m<sup>2</sup>

BILL OF MATERIALS				
DESCRIPTION	LENGTH/AREA Meter/Sq. Metere	MATERIAL	UNIT. WT	WT(Kg.)
SHS75x75x6	41.741	Gr.A / EQV.	12.51	525.74
UPN300	0.450	Gr.A / EQV.	46.2	20.52
6 mm THK. PLATE	4.009	Gr.A / EQV.	-	188.83
6 mm STEEL DIAMOND MESH	6.802	STEEL DIAMOND MESH	-	68.02
10 mm THK. PLATE	0.098	Gr.A / EQV.	-	7.71
16 mm THK. PLATE	0.035	Gr.A / EQV.	-	4.45
WOOD				
TOTAL				815.27

REFERENCE DRAWINGS		
NO.	DESCRIPTION	DRAWING NO.

REV NO.	DESCRIPTION	DRAWN	CHEKD	DATE	APPD.
0	ISSUED FOR CONSTRUCTION	SP	PM	31.01.2022	AD

RESERVED FOR STAMP

CLIENT: \_\_\_\_\_  
DATE: \_\_\_\_\_  
DRAWN: \_\_\_\_\_  
CHECKED: \_\_\_\_\_  
APPROVED: \_\_\_\_\_  
JOB: YARD FACILITY

DATE :	SCALE :	AS SHOWN
DRAWN :	HULL/JOB NO. :	-
CHECKED :	COST CODE NO. :	-
APPROVED :	DESIGNED BY :	
TITLE: MATERIAL LIFTING BASKET - 3.0 TON (3000x1400x1030)		
DRAWING NUMBER	SHT. No.	REV.
	1/2	0

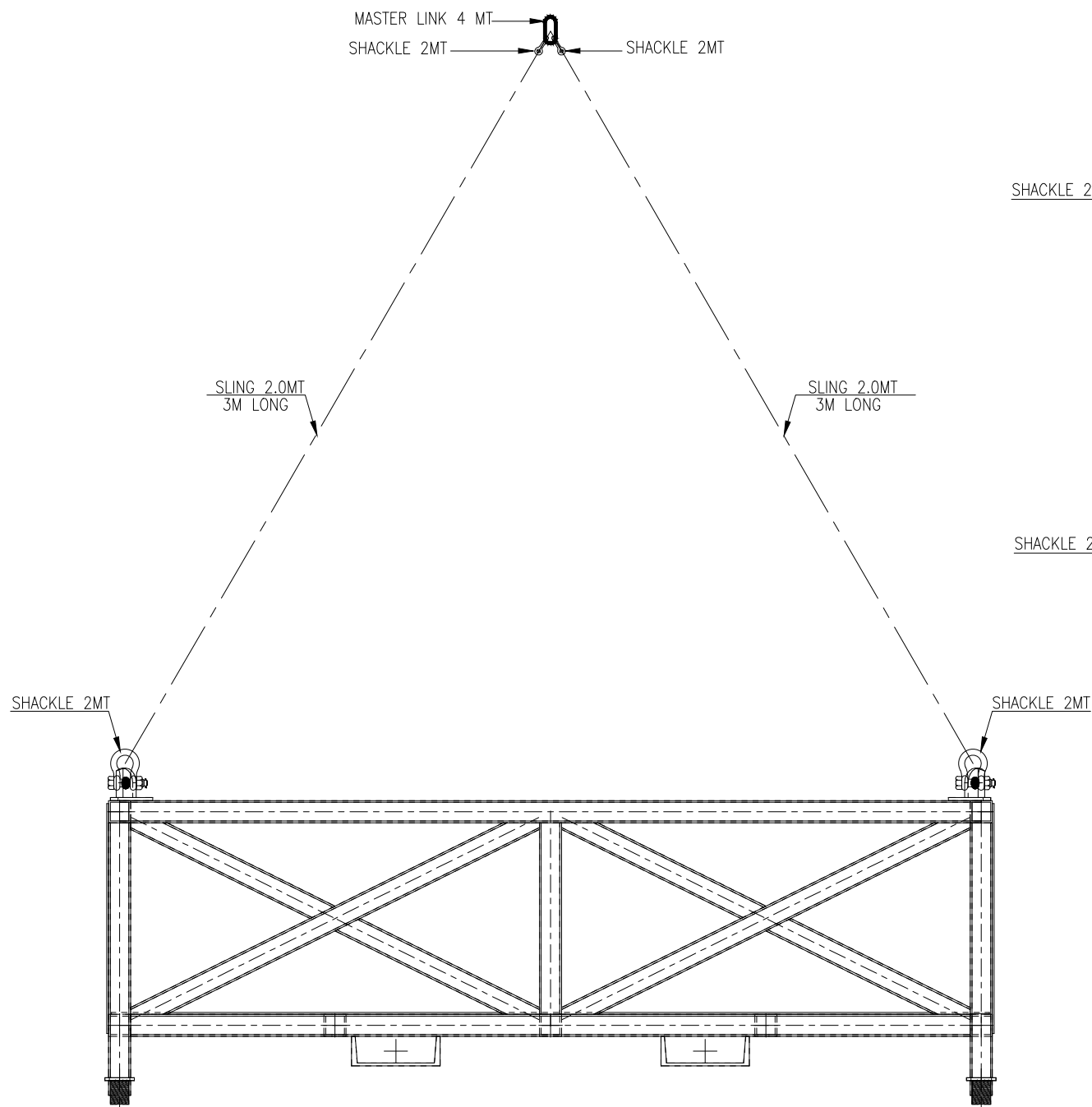

MATERIAL LIFTING BASKET (3.0 MT S.W.L.)  
FRONT EL.VIEW

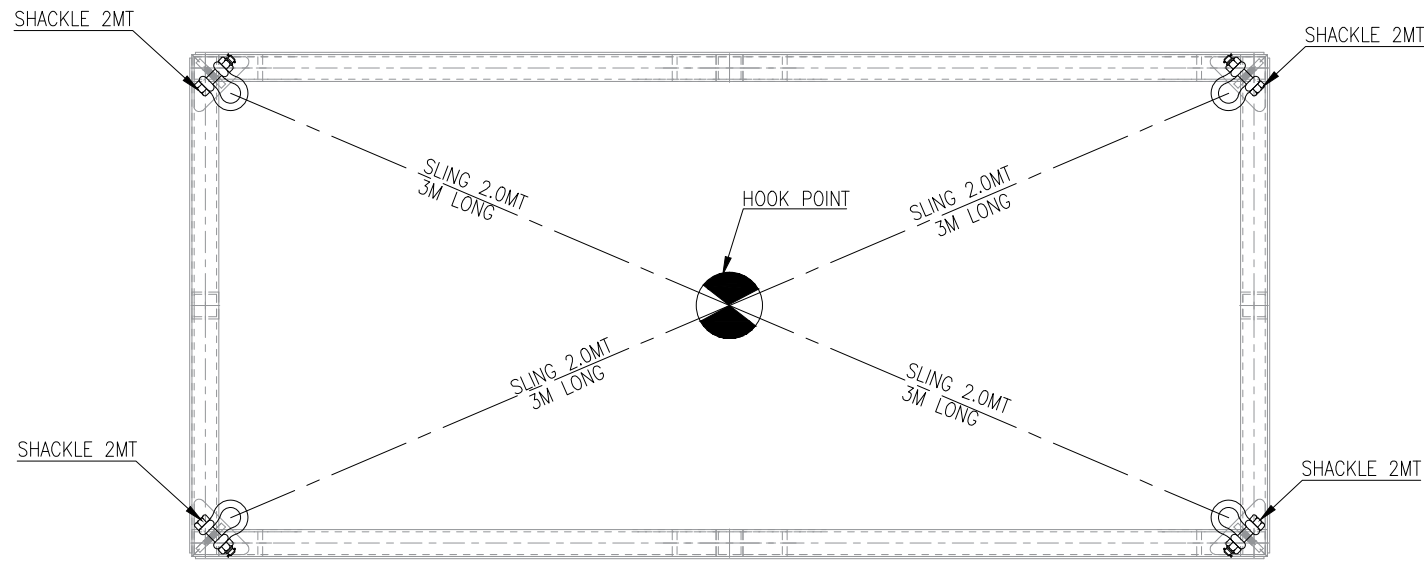

MATERIAL LIFTING BASKET (3.0 MT S.W.L.)  
UPPER PLAN VIEW

LIFTING ACCESSORIES		
ITEM	DESCRIPTION	QUANTITY NOS.
1	2MT S.W.L. SHACKLE (MIN. S.W.L.)	6
2	2.0MT S.W.L. WIRE SLING, 3m LENGTH (MIN.)	4
3	4MT S.W.L. MASTER LINK	1

NOTE: MINIMUM LIFTING ANGLE = 60°

MATERIAL BASKET (LIFTING PLAN ARRANGEMENT)

REFERENCE DRAWINGS			REV NO.	DESCRIPTION	DRAWN	CHEKD	DATE	APPD.	RESERVED FOR STAMP	CLIENT:	DATE :	SCALE :	AS SHOWN
NO.	DESCRIPTION	DRAWING NO.	0	ISSUED FOR CONSTRUCTION	SP	PM	31.01.2022	AD				DRAWN :	HULL/JOB NO. :
											CHECKED :	COST CODE NO. :	-
											APPROVED :	DESIGNED BY :	
											TITLE:	MATERIAL LIFTING BASKET - 3.0 TON (3000x1400x1030)	
										JOB:	DRAWING NUMBER		SHT. No.
										YARD FACILITY			2/2
													REV.
													0